



OFFICINE MARIO DORIN SINCE 1918

DORIN[®]
INNOVATION



CD SERIES

SEMI-HERMETIC MOTOR COMPRESSORS
TRANSCRITICAL CO₂ APPLICATION - 50/60 Hz



DORIN Web Software

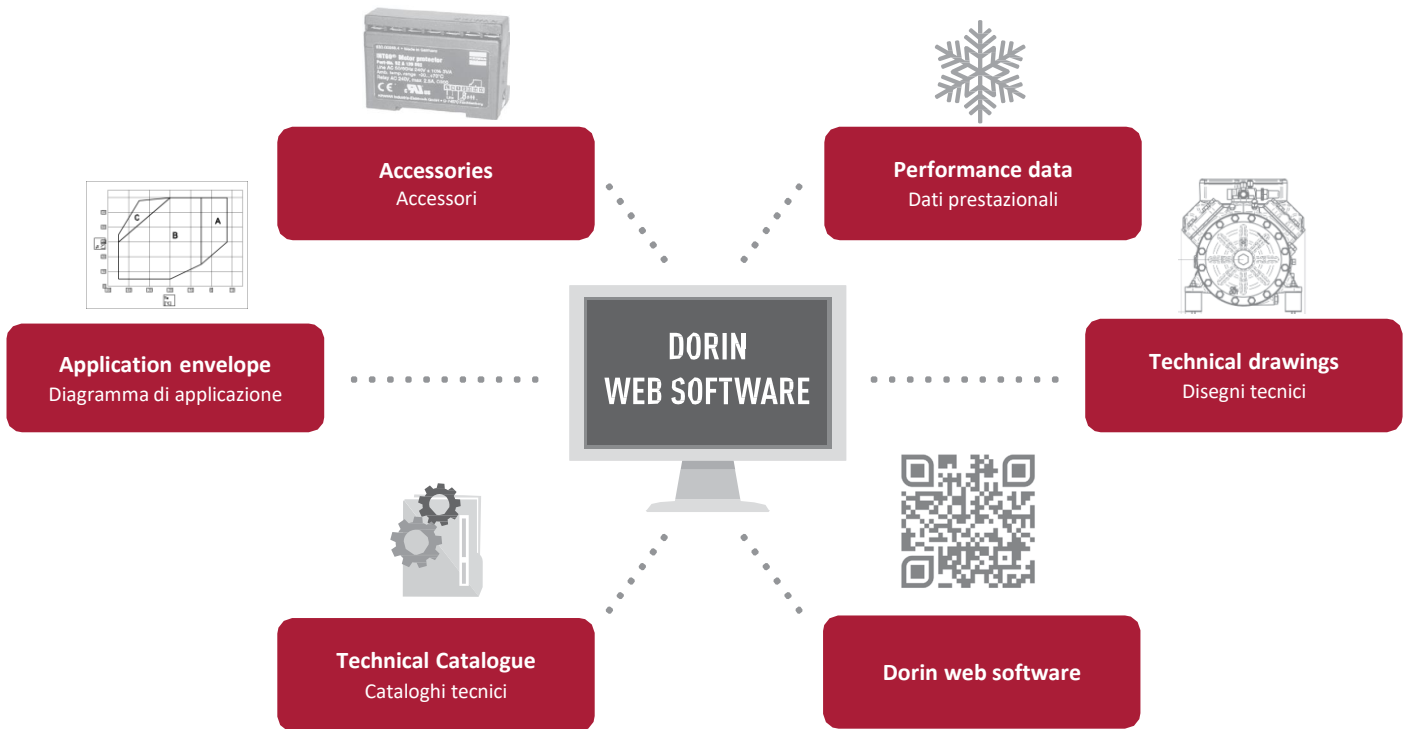

Frequency Range

Range di frequenza

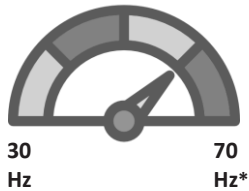

* Maximum operating frequency to be checked in the dedicated technical bulletin

* Controllare la massima frequenza operativa nel bollettino tecnico dedicato

Compressor certifications

Certificazioni di prodotto



Factory certifications

Certificazioni aziendali



ISO 4501:2018
ISO 9001:2015

CD Series Features

Caratteristiche della gamma CD



Silent operations and low vibrations

Basse vibrazioni ed estrema silenziosità

Crankshafts balanced individually and excellent fluid dynamics studies are our strengths

Ogni albero è bilanciato individualmente e studi CFD per ottimizzano i flussi interni



All models VFD compatible

Tutti i modelli possono essere utilizzati a frequenza variabile con inverter

Bore / Stroke values and generous motor sizings allow wide frequency ranges

Rapporti ottimizzati di alesaggio/corsa e motori generosamente dimensionati garantiscono un esteso funzionamento a frequenze variabili



Highest levels of efficiency

Livelli di efficienza ai vertici per compressori semiermetici

Using latest coating technologies for reducing frictions and improving lubrication

Trattamenti superficiali sui componenti in movimento per ridurre l'attrito e migliorare la lubrificazione



Peculiar oil containment system for extra low oil carry-over for models with oil pump

Soluzione tecnica di contenimento dell'olio peculiare per ridotti trascinamenti dell'olio sui modelli con pompa

Higher system efficiency, less oil injections from the oil-separator for higher oil viscosity in the compressor sump

Maggiore efficienza del sistema, ridotte iniezioni di olio dal separatore olio per una viscosità più alta dell'olio nel compressore



2 years standard warranty

2 anni di garanzia standard



All compressors suitable for CO2

Tutti i compressori possono lavorare con refrigerante CO2



Compact design and reduced gross weight

Dimensioni ridotte e peso contenuto

Optimized displacement values for crankcase size

Valori di spostamento volumetrico ottimizzati sulla taglia del corpo del compressore

CD Series Technical Features

Caratteristiche tecniche della gamma CD

1

Extra reliability and efficiency of optimized valve plate design

Estrema affidabilità ed efficienza del disegno delle piastre valvole

2

IP65 junction box

Scatola attacchi elettrici con isolamento IP65

3

Enhanced lubrication secured by automotive design

Miglior lubrificazione, garantita dal design automotive

4

Proven reliability of the electric motor thanks to the unique resistance to high temperatures

Dimostrata affidabilità del motore elettrico grazie alla straordinaria resistenza alle alte temperature

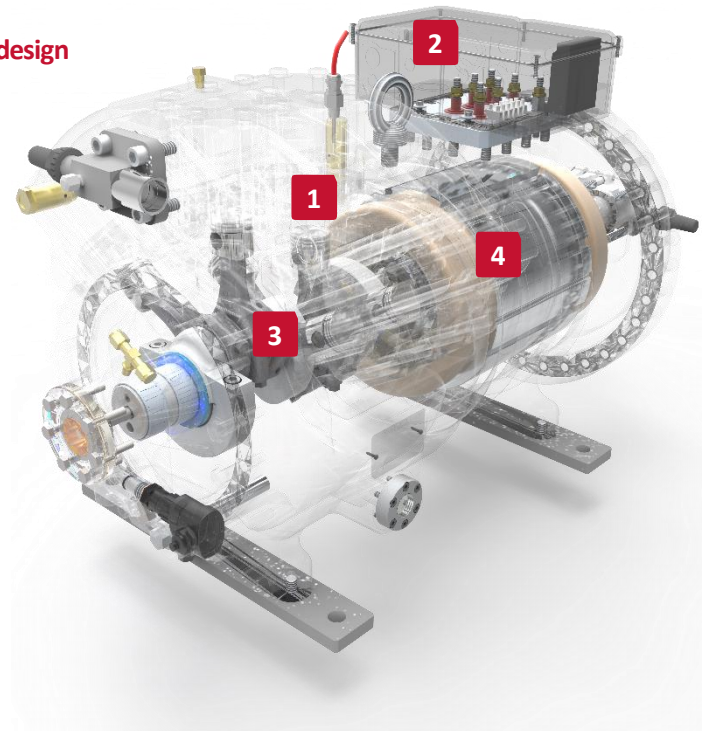

CD Series – Displacement 50 Hz

Serie CD – Spostamento volumetrico 50 Hz

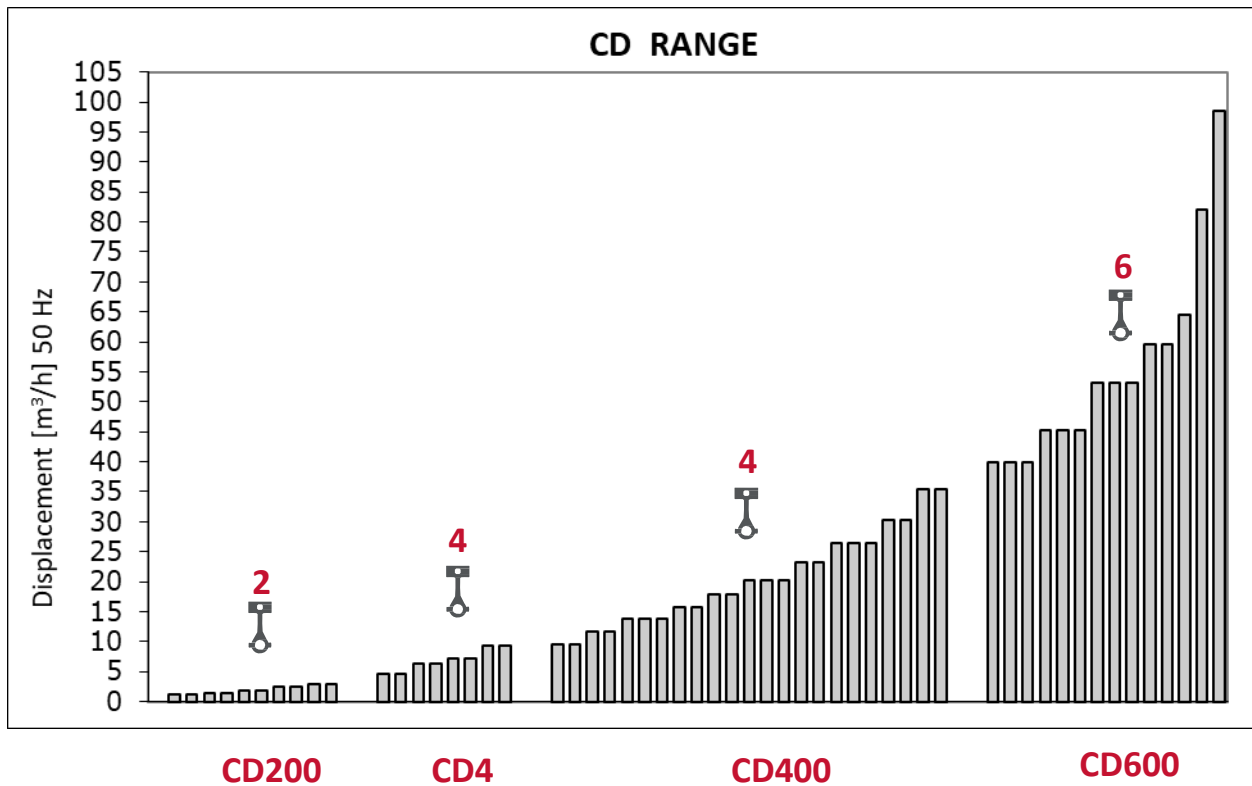

THE WIDEST CO₂ COMPRESSOR RANGE IN THE MARKET
FROM 1.12 m³/h UP TO 98.58 m³/h @ 50 Hz
CO₂ SINGLE STAGE TRANSCRITICAL COMPRESSORS

Model name

Nome modello



CD3500	H
MODEL MODELLO	H HIGH-MEDIUM EVAPORATING TEMPERATURE H TEMPERATURA DI EVAPORAZIONE MEDIO-ALTA
	M MEDIUM-LOW EVAPORATING TEMPERATURE M TEMPERATURA DI EVAPORAZIONE MEDIO-BASSA
	B LOW EVAPORATING TEMPERATURE B TEMPERATURA DI EVAPORAZIONE BASSA

Applications CD SERIES

Applicazioni per la gamma CD



Industrial Refrigeration
Refrigerazione Industriale



Railway HVAC
Condizionamento treni



Logistic Warehouse
Distribuzione



Heat Pumps
Pompe di calore



Commercial Refrigeration
Refrigerazione Commerciale



Bus A/C
Condizionamento Autobus



Refrigerated Transport
Trasporto refrigerato



Stationary HVAC
Aria condizionata

Standard And Optional Accessories

Accessori standard e opzionali



Motor Protection (MT)

Protezione motore (Mt)

CD200 range is equipped with the Thermik protection: a normally closed contact that trips in case the motor winding temperature is 140±5°C. From CD4 series and above compressors are equipped with a PTC probe on every motor winding set at 120°C. The sensor requires an external protection module to read the signal from the probe (BT008)

La gamma CD200 ha la protezione Thermik: un contatto normalmente chiuso che interrompe l'alimentazione al compressore se la temperatura degli avvolgimenti è 140±5°C. Dalla serie CD4 in su i compressori sono equipaggiati con un sensore PTC su ogni avvolgimento del motore impostato a 120 °C. Il sensore richiede un modulo di protezione esterno per leggere il segnale in uscita dalla PTC (BT008)





● STANDARD ○ OPTIONAL	MODEL			
	CD200	CD4	CD400	CD600
<p>Motor Protection (MT) Protezione motore (Mt)</p> <p>CD200 range is equipped with the Thermik protection: a normally closed contact that trips in case the motor winding temperature is 140±5°C. From CD4 series and above compressors are equipped with a PTC probe on every motor winding set at 120°C. The sensor requires an external protection module to read the signal from the probe (BT008)</p> <p>La gamma CD200 ha la protezione Thermik: un contatto normalmente chiuso che interrompe l'alimentazione al compressore se la temperatura degli avvolgimenti è 140±5°C. Dalla serie CD4 in su i compressori sono equipaggiati con un sensore PTC su ogni avvolgimento del motore impostato a 120 °C. Il sensore richiede un modulo di protezione esterno per leggere il segnale in uscita dalla PTC (BT008)</p>	●	●	●	●
<p>Electronic Protection Module (REL) Modulo elettronico protezione motore</p> <p>Keeping under constant control winding temperature and discharge temperature) (BT007)</p> <p>Modulo per controllare la temperatura degli avvolgimenti e quella di scarico (BT007)</p>	○	●	●	●
<p>Crankcase Heater (CH) Resistenza Carter</p> <p>The heater is 100 W for CD200 and CD4 included and 200 W for CD400 and CD600 series (BT001)</p> <p>Il riscaldatore ha una potenza di 100 W per la gamma CD200 e CD4 e 200 W per la gamma CD400 e CD600(BT001)</p>	○	○	○	○
<p>Self-regulating crankcase heater (TCH) Resistenza autoregolante (TCH)</p> <p>Increasing the energy efficiency and reducing the warm-up time. The thermal regulated crankcase heater reduces the output power once the set temperature is reached. Depending on the working conditions there is up to 30% energy saving compared to the standard heater (BT001)</p> <p>Rispetto alla resistenza standard CH riduce il tempo di riscaldamento e incrementa l'efficienza. La resistenza autoregolante aiuta a ridurre il consumo in potenza una volta che la temperatura di set è raggiunta. A seconda delle condizioni di funzionamento può garantire fino al 30 % di risparmio energetico rispetto alla resistenza standard (BT001)</p>	○	○	○	○
<p>Maximum discharge temperature sensor (TMAX) / Sonda di massima temperatura di scarico</p> <p>A thermistor probe is monitoring the discharge temperature to be kept below 130°C (BT007)</p> <p>Un termistore controlla la temperatura allo scarico con un set point a 130 °C (BT007)</p>	-	-	○	●



Standard And Optional Accessories

Accessori standard e opzionali

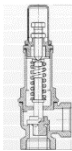

	MODEL			
	CD200	CD4	CD400	CD600
<p>● STANDARD ○ OPTIONAL</p>				
 <p>Oil differential pressure switch (ODPS) Sensore differenziale di pressione olio (ODPS) Compressors with oil pump are equipped with an oil differential pressure switch set at 0,95 bar differential. The oil pressure switch must be connected in series to both thermistors module and all other protections foreseen in the system chain alarm (BT007)</p> <p>I compressori equipaggiati con pompa olio utilizzano hanno un differenziale di pressione settato a 0,95 bar. La protezione per la pressione dell'olio deve essere connessa in serie a tutte le altre protezioni del compressore, come i termistori (BT007)</p>	-	-	○ ●	●
 <p>Oil charge Carica olio All compressors are charged in the factory with POE or PAG oil before the mechanical and electrical running tests</p> <p>Tutti i compressori sono caricati con olio POE o PAG prima dei test meccanici ed elettrici a fine linea di assemblaggio</p>	●	●	●	●
 <p>Head fan (BF) Ventilatore su testa Refer to DORIN software to know when this is needed (BT006)</p> <p>Fare riferimento al bollettino tecnico BT006 per sapere quando utilizzare questo accessorio</p>	-	○	○	○
 <p>Oil pump forced lubrication (FL) Lubrificazione mediante pompa olio (FL) CD400 range- optional for models CD1500M/CD2000H/CD1200B/CD2000M/CD2400H/CD1500B/CD2500H Not available for CD1200M/CD1400H Standard for other models.</p> <p>Gamma CD400: accessorio opzionale per i modelli CD1500M / CD2000H / CD1200B / CD2000M / CD2400H / CD1500B / CD2500H Non disponibile per CD1200M / CD1400H Standard per gli altri modelli</p>	-	-	○ ●	●
 <p>LP and HP valve (LPSV-HPSV) Valvola di sicurezza LP e HP</p>	●	●	●	●

CD SERIES

Oil Charge / Service Valves / Net Weight

Carica olio/ Rubinetti/ Peso netto



RANGE	MODEL	CYLINDERS	OIL CHARGE	SUCTION		DISCHARGE		NET WEIGHT
			(LITERS)	Socket welding (mm)	Butt welding (mm)	Socket welding (mm)	Butt welding (mm)	(kg)
CD200	CD 150M	2	1,3	10	14	10	14	71
	CD 180H	2	1,3	10	14	10	14	72
	CD 180M	2	1,3	10	14	10	14	73
	CD 300H	2	1,3	10	14	10	14	73
	CD 300M	2	1,3	10	14	10	14	73
	CD 350H	2	1,3	10	14	10	14	76
	CD 350M	2	1,3	10	14	10	14	76
	CD 360H	2	1,3	10	14	10	14	78
	CD 360M	2	1,3	10	14	10	14	77
	CD 380H	2	1,3	10	14	10	14	77
CD4	CD4 55-4,7M	4	1,7	22	28	18	24	117
	CD4 75-4,7H	4	1,7	22	28	18	24	117
	CD4 75-6,4M	4	1,7	22	28	18	24	117
	CD4 90-6,4H	4	1,7	22	28	18	24	117
	CD4 75-7,3M	4	1,7	22	28	18	24	120
	CD4 90-7,3H	4	1,7	22	28	18	24	120
	CD4 90-9,2M	4	1,7	22	28	18	24	119
	CD4 120-9,2H	4	1,7	22	28	18	24	121
CD400	CD 1200M	4	2,5	22	28	22	28	164
	CD 1400H	4	2,5	22	28	22	28	164
	CD 1500M	4	2,5	22	28	22	28	164
	CD 2000H	4	2,5	22	28	22	28	164
	CD 1200B	4	2,5	22	28	22	28	164
	CD 2000M	4	2,5	22	28	22	28	164
	CD 2400H	4	2,5	22	28	22	28	168
	CD 1500B	4	2,5	22	28	22	28	164
	CD 2500H	4	2,5	22	28	22	28	168
	CD 2500M	4	2,5	22	28	22	28	172
	CD 3000H	4	2,5	22	28	22	28	178
	CD 2001B	4	2,5	22	28	22	28	168
	CD 3001M	4	2,5	22	28	22	28	178
	CD 3401H	4	2,5	22	28	22	28	187
	CD 2501B	4	2,5	22	28	22	28	172
	CD 3501H	4	2,5	22	28	22	28	187
	CD 3001B	4	2,5	22	28	22	28	178
	CD 3501M	4	2,5	22	28	22	28	187
	CD 4501H	4	2,5	22	28	22	28	199
	CD 3501B	4	2,5	28	35	22	28	199
CD 5001M	4	2,5	28	35	22	28	202	
CD 4001B	4	2,5	28	35	22	28	199	
CD 5201M	4	2,5	28	35	22	28	202	
CD600	CD6 501-40B	6	4,8	42s	-	28s	35	415
	CD6 601-40M	6	4,8	42s	-	28s	35	425
	CD6 701-40H	6	4,8	42s	-	28s	35	448
	CD6 501-45B	6	4,8	42s	-	28s	35	422
	CD6 701-45M	6	4,8	42s	-	28s	35	448
	CD6 801-45H	6	4,8	42s	-	28s	35	460
	CD6 501-53B	6	4,8	42s	-	28s	35	422
	CD6 801-53M	6	4,8	42s	-	28s	35	460
	CD6 901-53H	6	4,8	42s	-	28s	35	445
	CD6 601-59B	6	4,8	42s	-	28s	35	428
	CD6 901-59M	6	4,8	42s	-	28s	35	452
	CD6 701-65B	6	4,5	54s	-	35s	-	444
	CD6 801-82B	6	4,5	54s	-	35s	-	456
CD6 801-99B	6	4,5	54s	-	42s	-	476	

CD SERIES

Electric Motor FLA (Full Load Ampere)

Massima corrente di funzionamento FLA (Full Load Ampere)

RANGE	MODEL	DISPLACEMENT		MAX OPERATING CURRENT V / ph / Hz [A]													MAX ABSORBED POWER		
		50 Hz [m3/h]	60 Hz [m3/h]	220-240 / 1 / 50	208-230 / 1 / 60	115 / 1 / 60	D		208-230 / 3 / 60 D	360-400 / 3 / 60 Y	200 / 3 / 50-60 D	PWS		220-240 / 3 / 50 PWS	208-230 / 3 / 60 PWS	360-400 / 3 / 60 PWS	475-525 / 3 / 50 570-630 / 3 / 60	50 Hz [kW]	60 Hz [kW]
							220-240 / 3 / 50 D	265-290 / 3 / 60 D				380-420 / 3 / 50 Y	440-480 / 3 / 60 Y						
CD200	CD 150M	1,12	1,35	-	-	-	5,9	3,4	7,1	4,1	-	-	-	-	-	2,7	2,0	2,4	
	CD 180H	1,12	1,35	-	-	-	7,6	4,4	9,1	5,3	-	-	-	-	-	3,5	2,6	3,2	
	CD 180M	1,46	1,76	-	-	-	7,6	4,4	9,1	5,3	-	-	-	-	-	3,5	2,6	3,2	
	CD 300H	1,46	1,76	-	-	-	10,4	6,0	12,5	7,2	-	-	-	-	-	4,8	3,6	4,4	
	CD 300M	1,88	2,25	-	-	-	10,4	6,0	12,5	7,2	-	-	-	-	-	4,8	3,6	4,4	
	CD 350H	1,88	2,25	-	-	-	12,6	7,3	15,1	8,7	-	-	-	-	-	5,8	4,2	5,1	
	CD 350M	2,39	2,87	-	-	-	12,6	7,3	15,1	8,7	-	-	-	-	-	5,8	4,2	5,1	
	CD 360H	2,39	2,87	-	-	-	16,2	9,4	19,4	11,2	-	-	-	-	-	7,5	5,5	6,6	
CD 360M	3,00	3,6	-	-	-	12,9	7,5	15,5	8,9	-	-	-	-	-	6,0	4,4	5,3		
CD 380H	3,00	3,6	-	-	-	16,2	9,4	19,4	11,2	-	-	-	-	-	7,5	5,5	6,6		
CD4	CD4 55-4,7M	4,67	5,6	-	-	-	25,0	14,5	30,0	17,4	-	14,5	-	-	-	11,6	8,7	10,5	
	CD4 75-4,7H	4,67	5,6	-	-	-	34,0	19,5	41,0	23,5	-	19,5	-	-	-	15,6	11,4	13,7	
	CD4 75-6,4M	6,40	7,68	-	-	-	34,0	19,5	41,0	23,5	-	19,5	-	-	-	15,6	11,4	13,7	
	CD4 90-6,4H	6,40	7,68	-	-	-	40,0	23,0	48,0	27,5	-	23,0	-	-	-	18,4	13,8	16,6	
	CD4 75-7,3M	7,28	8,74	-	-	-	34,0	19,5	41	23,5	-	19,5	-	-	-	15,6	11,4	13,7	
	CD4 90-7,3H	7,28	8,74	-	-	-	40,0	23,0	48,0	27,5	-	23,0	-	-	-	18,4	13,8	16,6	
	CD4 90-9,2M	9,21	11,05	-	-	-	40,0	23,0	48	27,5	-	23,0	-	-	-	18,4	13,8	16,6	
	CD4 120-9,2H	9,21	11,05	-	-	-	41,5	24,0	50	28,8	-	24,0	-	-	-	19,2	14,5	17,4	
CD400	CD 1200M	9,48	11,37	-	-	-	48,5	28,0	58	33,5	-	28,0	48,5	58	33,5	22,5	16,8	20,2	
	CD 1400H	9,48	11,37	-	-	-	59	34,0	71	41,0	-	34,0	59	71	41,0	27,0	19,5	23,4	
	CD 1500M	11,69	14,03	-	-	-	59	34,0	71	41,0	-	34,0	59	71	41,0	27,0	19,5	23,4	
	CD 2000H	11,69	14,03	-	-	-	66	38,0	79	45,5	-	38,0	66	79	45,5	30,5	22,7	27,2	
	CD 1200B	13,84	16,61	-	-	-	48,5	28,0	58	33,5	-	28,0	48,5	58	33,5	22,5	16,8	20,2	
	CD 2000M	13,84	16,61	-	-	-	66	38,0	79	45,5	-	38,0	66	79	45,5	30,5	22,7	27,2	
	CD 2400H	13,84	16,61	-	-	-	78	45,0	93	54	-	45,0	78	93	54	36,0	26,6	31,9	
	CD 1500B	15,72	18,86	-	-	-	59	34,0	71	41,0	-	34,0	59	71	41,0	27,0	19,5	23,4	
	CD 2500H	15,72	18,86	-	-	-	78	45,0	93	54	-	45,0	78	93	54	36,0	26,6	31,9	
	CD 2500M	17,84	21,41	-	-	-	78	45,0	93	54	-	45,0	78	93	54	36,0	26,6	31,9	
	CD 3000H	17,84	21,41	-	-	-	97	56	116	67	-	56	97	116	67	45,0	33,4	40,1	
	CD 2001B	20,15	24,18	-	-	-	66	38,0	79	45,5	-	38,0	66	79	45,5	30,5	22,7	27,2	
	CD 3001M	20,15	24,18	-	-	-	97	56	116	67	-	56	97	116	67	45,0	33,4	40,1	
	CD 3401H	20,15	24,18	-	-	-	130	75	156	90	-	75	130	156	90	60	44,9	53,9	
	CD 2501B	23,3	27,96	-	-	-	78	45,0	93	54	-	45,0	78	93	54	36,0	26,6	31,9	
	CD 3501H	23,3	27,96	-	-	-	130	75	156	90	-	75	130	156	90	60	44,9	53,9	
	CD 3001B	26,45	31,74	-	-	-	97	56	116	67	-	56	97	116	67	45,0	33,4	40,1	
	CD 3501M	26,45	31,74	-	-	-	130	75	156	90	-	75	130	156	90	60	44,9	53,9	
	CD 4501H	26,45	31,74	-	-	-	139	80	166	96	-	80	139	166	96	64	48,4	58,1	
	CD 3501B	31,04	37,25	-	-	-	130	75	156	90	-	75	130	156	90	60	44,9	53,9	
CD 5001M	31,04	37,25	-	-	-	161	93	193	112	-	93	161	193	112	74	56,6	67,9		
CD 4001B	35,47	42,56	-	-	-	139	80	166	96	-	80	139	166	96	64	48,4	58,1		
CD 5201M	35,47	42,56	-	-	-	161	93	193	112	-	19,5	161	193	112	74	56,6	67,9		

Electric Motor FLA (Full Load Ampere)

Massima corrente di funzionamento FLA (Full Load Ampere)



RANGE	MODEL	DISPLACEMENT		MAX OPERATING CURRENT V / ph / Hz [A]													MAX ABSORBED POWER	
		50 Hz [m3/h]	60 Hz [m3/h]	220-240 / 1 / 50	208-230 / 1 / 60	115 / 1 / 60	220-240 / 3 / 50 265-290 / 3 / 60 D	380-420 / 3 / 50 440-480 / 3 / 60 Y	208-230 / 3 / 60 D	360-400 / 3 / 60 Y	200 / 3 / 50-60 D	380-420 / 3 / 50 440-480 / 3 / 60 PWS	220-240 / 3 / 50 PWS	208-230 / 3 / 60 PWS	360-400 / 3 / 60 PWS	475-525 / 3 / 50 570-630 / 3 / 60	50 Hz [kW]	60 Hz [kW]
CD600	CD6 501-40B	39,85	47,82	-	-	-	156	90	187	108	-	90	156	187	108	72	52,4	62,9
	CD6 601-40M	39,85	47,82	-	-	-	182	105	218	126	-	105	182	218	126	84	62,0	74,4
	CD6 701-40H	39,85	47,82	-	-	-	208	120	249	144	-	120	208	249	144	96	73,0	87,6
	CD6 501-45B	45,34	54,41	-	-	-	156	90	187	108	-	90	156	187	108	72	52,4	62,9
	CD6 701-45M	45,34	54,41	-	-	-	208	120	249	144	-	120	208	249	144	96	73,0	87,6
	CD6 801-45H	45,34	54,41	-	-	-	256	148	308	178	-	148	256	308	178	118	83,0	99,6
	CD6 501-53B	53,21	63,85	-	-	-	156	90	187	108	-	90	156	187	108	72	52,4	62,9
	CD6 801-53M	53,21	63,85	-	-	-	256	148	308	178	-	148	256	308	178	118	83,0	99,6
	CD6 901-53H	53,21	63,85	-	-	-	294	170	353	204	-	170	294	353	204	136	99,2	119,0
	CD6 601-59B	59,53	71,44	-	-	-	182	105	218	126	-	105	182	218	126	84	62,0	74,4
	CD6 901-59M	59,53	71,44	-	-	-	294	170	353	204	-	170	294	353	204	136	99,2	119,0
	CD6 701-65B	64,49	77,39	-	-	-	208	120	249	144	-	120	208	249	144	96	73,0	87,6
	CD6 801-82B	81,95	98,34	-	-	-	256	148	308	178	-	148	256	308	178	118	83,0	99,6
	CD6 901-99B	98,58	118,3	-	-	-	294	170	353	204	-	170	294	353	204	136	99,2	119,0

Standard version of the motor / contact our technical service for operating conditions not present in the catalog

Versione standard del motore/contattare il nostro ufficio tecnico commerciale per le condizioni non presenti sul catalogo

Electric Motor LRA (Locked Rotor Ampere)

Corrente a rotore bloccato LRA (Locked Rotor Ampere)



RANGE	MODEL	DISPLACEMENT		LOCKED ROTOR CURRENT V / ph / Hz [A]												
		50 Hz [m3/h]	60 Hz [m3/h]	220-240 / 1 / 50	208-230 / 1 / 60	115 / 1 / 60	220-240 / 3 / 50 265-290 / 3 / 60 D	380-420 / 3 / 50 440-480 / 3 / 60 Y	208-230 / 3 / 60 D	360-400 / 3 / 60 Y	200 / 3 / 50-60 D	380-420 / 3 / 50 440-480 / 3 / 60 PWS *	220-240 / 3 / 50 PWS *	208-230 / 3 / 60 PWS *	360-400 / 3 / 60 PWS *	475-525 / 3 / 50 570-630 / 3 / 60
CD200	CD 150M	1,12	1,35	-	-	-	27,0	15,5	32,5	18,7	-	-	-	-	-	12,4
	CD 180H	1,12	1,35	-	-	-	35,0	20,0	41,5	24,0	-	-	-	-	-	16,0
	CD 180M	1,46	1,76	-	-	-	35,0	20,0	41,5	24,0	-	-	-	-	-	16,0
	CD 300H	1,46	1,76	-	-	-	42,0	24,5	51	29,5	-	-	-	-	-	19,6
	CD 300M	1,88	2,25	-	-	-	42,0	24,5	51	29,5	-	-	-	-	-	19,6
	CD 350H	1,88	2,25	-	-	-	55	32,0	66	38,5	-	-	-	-	-	25,5
	CD 350M	2,39	2,87	-	-	-	55	32,0	66	38,5	-	-	-	-	-	25,5
	CD 360H	2,39	2,87	-	-	-	76	43,5	91	52	-	-	-	-	-	35,0
CD4	CD4 55-4,7M	4,67	5,6	-	-	-	109	63	131	76	-	63	-	-	-	50
	CD4 75-4,7H	4,67	5,6	-	-	-	149	86	179	103	-	86	-	-	-	69
	CD4 75-6,4M	6,40	7,68	-	-	-	149	86	179	103	-	86	-	-	-	69
	CD4 90-6,4H	6,40	7,68	-	-	-	159	92	191	110	-	92	-	-	-	74
	CD4 75-7,3M	7,28	8,74	-	-	-	149	86	179	103	-	86	-	-	-	69
	CD4 90-7,3H	7,28	8,74	-	-	-	159	92	191	110	-	92	-	-	-	74
	CD4 90-9,2M	9,21	11,05	-	-	-	159	92	191	110	-	92	-	-	-	74
	CD4 120-9,2H	9,21	11,05	-	-	-	189	109	226	190	-	109	-	-	-	87
CD400	CD 1200M	9,48	11,37	-	-	-	233	135	280	162	-	135	233	280	162	108
	CD 1400H	9,48	11,37	-	-	-	295	171	354	205	-	171	295	354	205	136
	CD 1500M	11,69	14,03	-	-	-	295	171	354	205	-	171	295	354	205	136
	CD 2000H	11,69	14,03	-	-	-	306	177	367	212	-	177	306	367	212	142
	CD 1200B	13,84	16,61	-	-	-	233	135	280	162	-	135	233	280	162	108
	CD 2000M	13,84	16,61	-	-	-	306	177	367	212	-	177	306	367	212	142
	CD 2400H	13,84	16,61	-	-	-	351	203	421	244	-	203	351	421	244	162
	CD 1500B	15,72	18,86	-	-	-	295	171	354	205	-	171	295	354	205	136
	CD 2500H	15,72	18,86	-	-	-	351	203	421	244	-	203	351	421	244	162
	CD 2500M	17,84	21,41	-	-	-	351	203	421	244	-	203	351	421	244	162
	CD 3000H	17,84	21,41	-	-	-	424	245	509	294	-	245	424	509	294	196
	CD 2001B	20,15	24,18	-	-	-	306	177	367	212	-	177	306	367	212	142
	CD 3001M	20,15	24,18	-	-	-	424	245	509	294	-	245	424	509	294	196
	CD 3401H	20,15	24,18	-	-	-	450	260	540	312	-	260	450	540	312	208
	CD 2501B	23,3	27,96	-	-	-	351	203	421	244	-	203	351	421	244	162
	CD 3501H	23,3	27,96	-	-	-	450	260	540	312	-	260	450	540	312	208
	CD 3001B	26,45	31,74	-	-	-	424	245	509	294	-	245	424	509	294	196
	CD 3501M	26,45	31,74	-	-	-	450	260	540	312	-	260	450	540	312	208
	CD 4501H	26,45	31,74	-	-	-	559	323	671	388	-	323	559	671	388	258
	CD 3501B	31,04	37,25	-	-	-	450	260	540	312	-	260	450	540	312	208
CD 5001M	31,04	37,25	-	-	-	559	323	671	388	-	323	559	671	388	258	
CD 4001B	35,47	42,56	-	-	-	502	290	602	348	-	290	502	602	348	232	
CD 5201M	35,47	42,56	-	-	-	559	323	671	388	-	323	559	671	388	258	

Electric Motor LRA (Locked Rotor Ampere)

Corrente a rotore bloccato LRA (Locked Rotor Ampere)

RANGE	MODEL	DISPLACEMENT		LOCKED ROTOR CURRENT V / ph / Hz [A]												
		50 Hz [m3/h]	60 Hz [m3/h]	220-240 / 1 / 50	208-230 / 1 / 60	115 / 1 / 60	220-240 / 3 / 50 265-290 / 3 / 60 D	380-420 / 3 / 50 440-480 / 3 / 60 Y	208-230 / 3 / 60 D	360-400 / 3 / 60 Y	200 / 3 / 50-60 D	380-420 / 3 / 50 440-480 / 3 / 60 PWS *	220-240 / 3 / 50 PWS *	208-230 / 3 / 60 PWS *	360-400 / 3 / 60 PWS *	475-525 / 3 / 50 570-630 / 3 / 60
CD600	CD6 501-40B	39,85	47,82	-	-	-	636	367	763	440	-	367	636	763	440	294
	CD6 601-40M	39,85	47,82	-	-	-	788	455	946	546	-	455	788	946	546	364
	CD6 701-40H	39,85	47,82	-	-	-	942	544	1131	653	-	544	942	1131	653	435
	CD6 501-45B	45,34	54,41	-	-	-	636	367	763	440	-	367	636	763	440	294
	CD6 701-45M	45,34	54,41	-	-	-	942	544	1131	653	-	544	942	1131	653	435
	CD6 801-45H	45,34	54,41	-	-	-	1012	584	1214	701	-	584	1012	1214	701	467
	CD6 501-53B	53,21	63,85	-	-	-	636	367	763	440	-	367	636	763	440	294
	CD6 801-53M	53,21	63,85	-	-	-	1012	584	1214	701	-	584	1012	1214	701	467
	CD6 901-53H	53,21	63,85	-	-	-	1143	660	1372	792	-	660	1143	1372	792	528
	CD6 601-59B	59,53	71,44	-	-	-	788	455	946	546	-	455	788	946	546	364
	CD6 901-59M	59,53	71,44	-	-	-	1143	660	1372	792	-	660	1143	1372	792	528
	CD6 701-65B	64,49	77,39	-	-	-	942	544	1131	653	-	544	942	1131	653	435
	CD6 801-82B	81,95	98,34	-	-	-	1012	584	1214	701	-	584	1012	1214	701	467
	CD6 901-99B	98,58	118,3	-	-	-	1143	660	1372	792	-	660	1143	1372	792	528

* The current value refers to the direct connection.

*Valore per collegamento diretto

Standard version of the motor / contact our technical service for operating conditions not present in the catalog

Versione standard del motore/contattare il nostro ufficio tecnico commerciale per le condizioni non presenti sul catalogo

Application Envelope

Diagrammi di applicazione

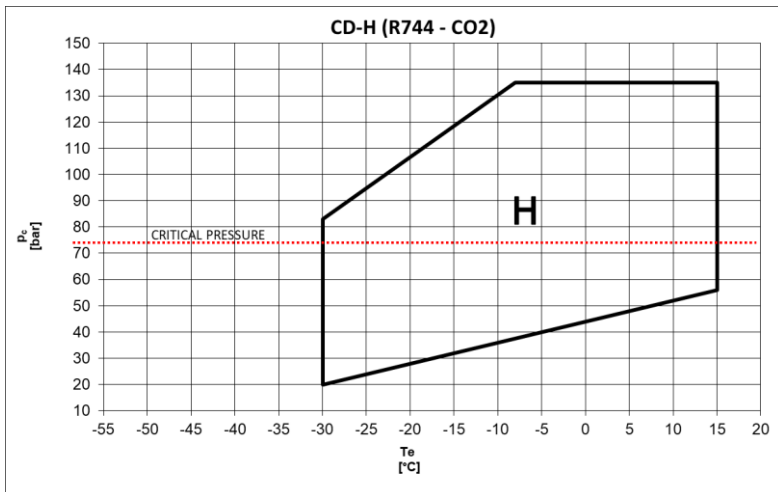
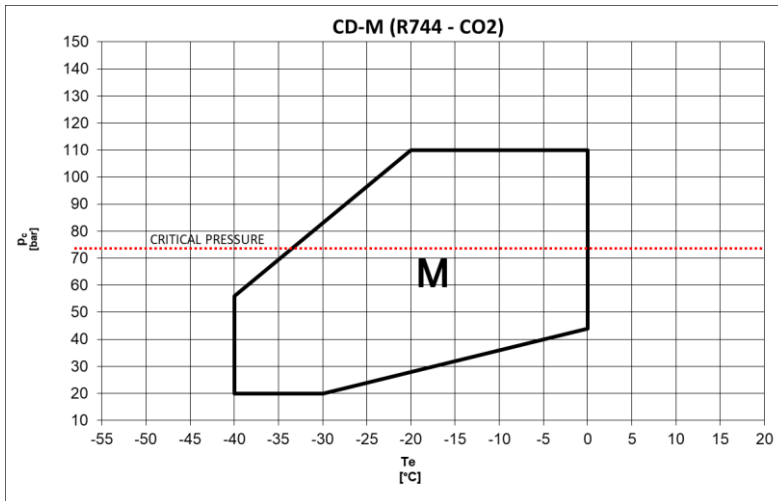
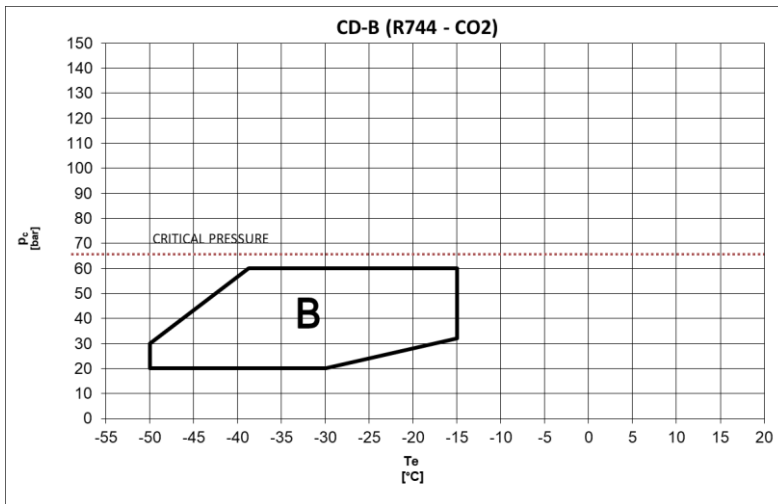

CD200-CD4-CD400

The application envelope changes with the compressor model and is available for every model in the DORIN web software

Il diagramma di applicazione cambia con il modello di compressore ed è disponibile per ogni modello e refrigerante nel web software di DORIN

Compressors application envelopes valid for superheat values lower than 10K

Diagramma di applicazione validi per surriscaldamenti in aspirazione non superiori a 10K

Application Envelope

Diagrammi di applicazione

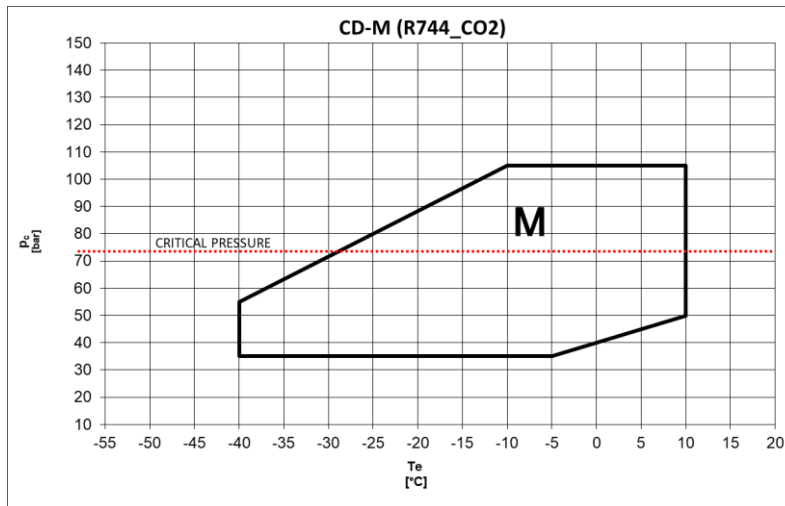
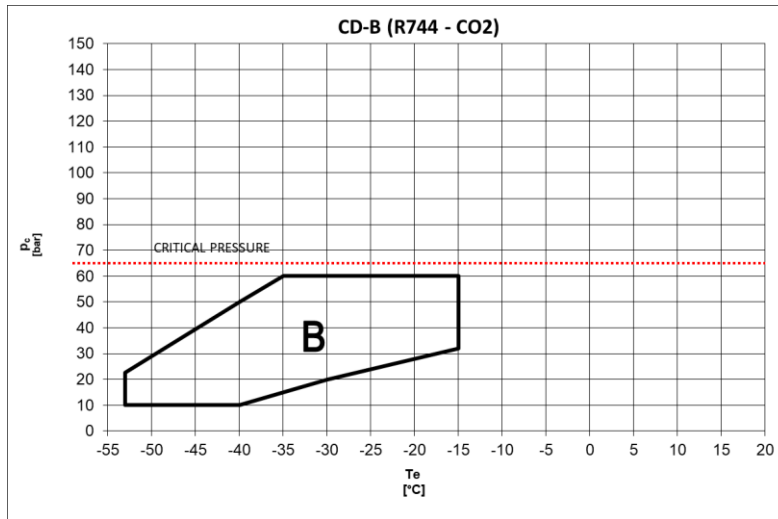

CD600

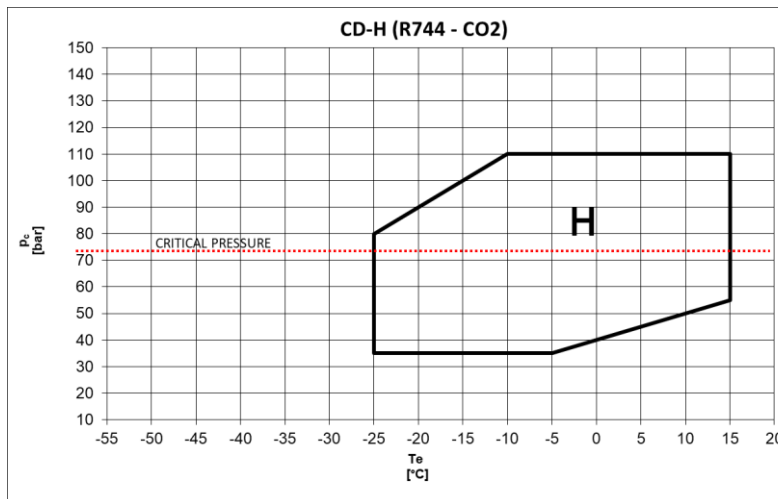

The application envelope changes with the compressor model and is available for every model in the DORIN web software

Il diagramma di applicazione cambia con il modello di compressore ed è disponibile per ogni modello e refrigerante nel web software di DORIN

Compressors application envelopes valid for superheat values lower than 10K

Diagramma di applicazione validi per surriscaldamenti in aspirazione non superiori a 10K

Technical Drawings

Disegno tecnico



CD200

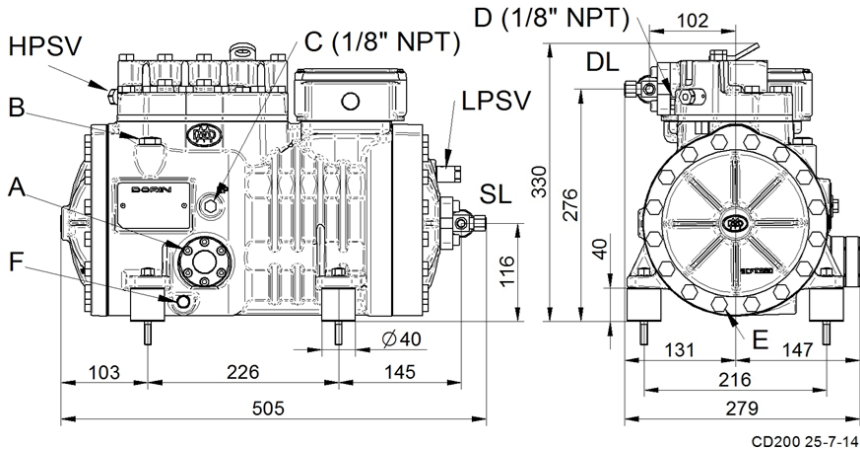

MODEL MODELLO
CD 150M
CD 180H
CD 180M
CD 300H
CD 300M
CD 350H
CD 350M
CD 360H
CD 360M
CD 380H

CD4

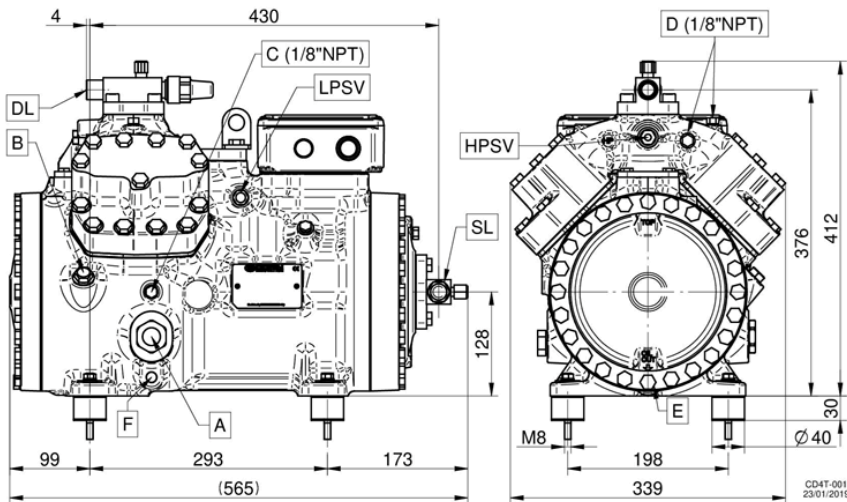

MODEL MODELLO
CD4 55-4,7M
CD4 75-4,7H
CD4 75-6,4M
CD4 90-6,4H
CD4 75-7,3M
CD4 90-7,3H
CD4 90-9,2M
CD4 120-9,2H

A - Oil sight - Spia Olio

B - Oil charge plug - Tappo carica Olio (M12)

C - Low pressure tap - Presa Bassa Pres. (1/8" NPT)

D - High pressure tap - Presa Alta Pres. (1/8" NPT)

E - Oil drain plug - Tappo scarica olio

F - Crankcase heater - Resistenza carter

DL - Discharge service valve - Rubinetto Compressione

SL - Suction service valve - Rubinetto Aspirazione

LPSV - LP safety valve - Valvola sicurezza LP

HPSV - HP safety valve - Valvola sicurezza HP

Technical Drawings

Disegno tecnico



CD400

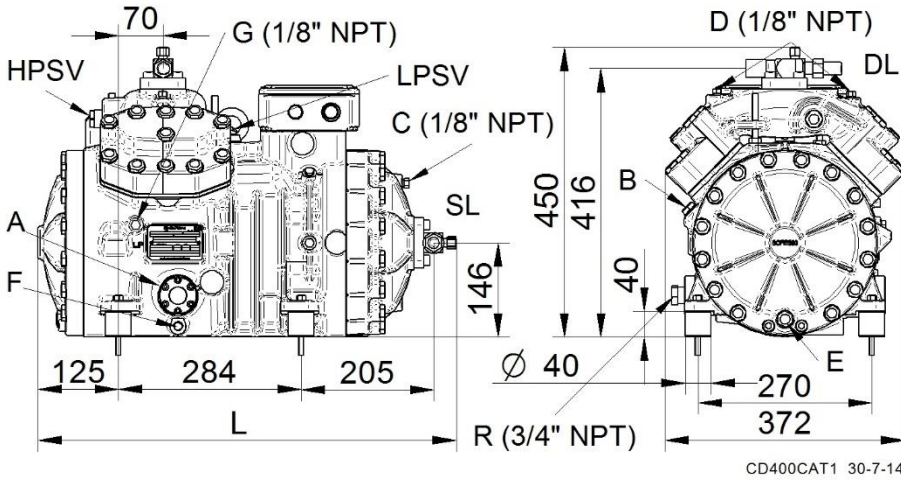

Figure/Figura 1

MODEL MODELLO	Fig.	L	KS
		(mm)	(mm)
CD 1200M	1	650	---
CD 1400H	1	650	---
CD 1500M *	1*	650 *	---
CD 2000H *	1*	650 *	---
CD 1200B *	1*	650 *	---
CD 2000M *	1*	650 *	---
CD 2400H *	1*	650 *	---
CD 1500B *	1*	650 *	---
CD 2500H *	1*	650 *	---
CD 2500M	2	690	208
CD 3000H	2	740	259
CD 2001B	2	690	208
CD 3001M	2	740	259
CD 3401H	2	740	259
CD 2501B	2	690	208
CD 3500H	2	740	259
CD 3001B	2	740	259
CD 3501M	2	740	259
CD 4501H	2	780	300
CD 3501B	2	750	264
CD 5001M	2	790	305
CD 4001B	2	790	305
CD 5201M	2	790	305

CD400

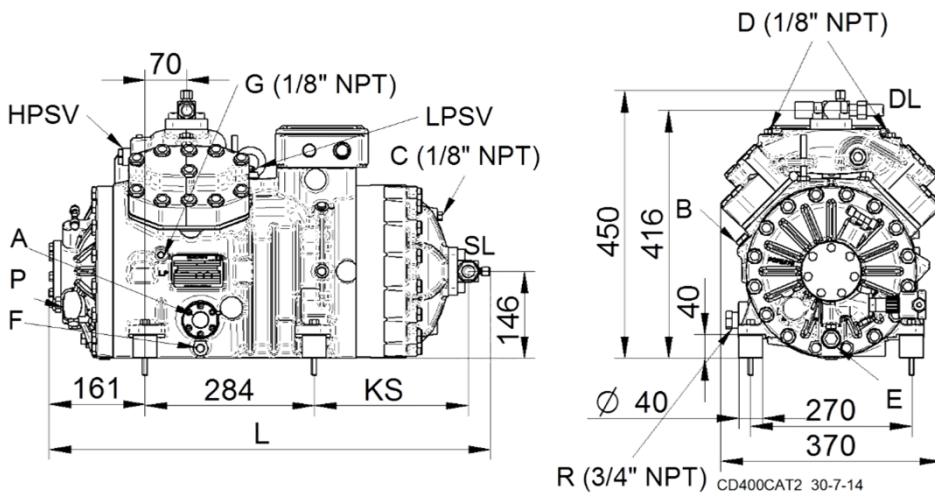

Figure/Figura 2

*For this models, figure III (with L = 685 mm) becomes the reference figure if the oil pump is requested as accessory

*Per questi modelli, la figura III (con L=685 mm) diventa la figura di riferimento se la pompa olio è richiesta come accessorio

- A** - Oil sight - Spia Olio
- B** - Oil charge plug - Tappo carica Olio (M12)
- C** - Low pressure tap - Presa Bassa Pres. (1/8" NPT)
- D** - High pressure tap - Presa Alta Pres. (1/8" NPT)
- E** - Oil drain plug - Tappo scarica olio
- F** - Crankcase heater - Resistenza carter
- G** - Oil return plug - Tappo ritorno olio (1/8" NPT)

- P** - Oil diff. press. Switch - Press. diff. olio elettr.
- R** - Oil level connection - Connessione livello olio
- DL** - Discharge service valve - Rubinetto Compressione
- SL** - Suction service valve - Rubinetto Aspirazione
- LPSV** - LP safety valve - Valvola sicurezza LP
- HPSV** - HP safety valve - Valvola sicurezza HP

Technical Drawings

Disegno tecnico



CD600

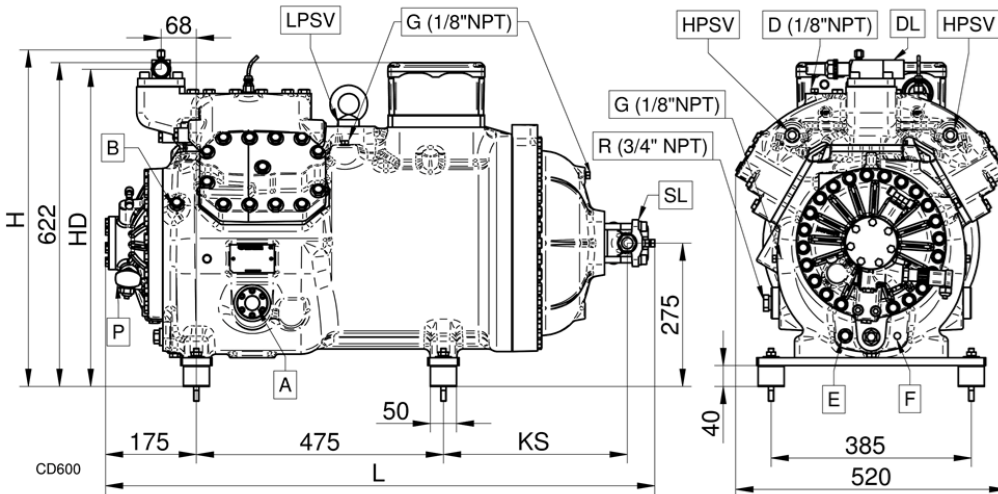

MODEL MODELLO
CD6 501-40B
CD6 601-40M
CD6 701-40H
CD6 501-45B
CD6 701-45M
CD6 801-45H
CD6 501-53B
CD6 801-53M
CD6 901-53H
CD6 601-59B
CD6 901-59M
CD6 701-65B
CD6 801-82B
CD6 901-99B

- A** - Oil sight - Spia Olio
- B** - Oil charge plug - Tappo carica Olio (M12)
- C** - Low pressure tap - Presa Bassa Pres. (1/8" NPT)
- D** - High pressure tap - Presa Alta Pres. (1/8" NPT)
- E** - Oil drain plug - Tappo scarica olio
- F** - Crankcase heater - Resistenza carter
- G** - Oil return plug - Tappo ritorno olio (1/8" NPT)

- P** - Oil diff. press. Switch - Press. diff. olio elettr.
- R** - Oil level connection - Connessione livello olio
- DL** - Discharge service valve - Rubinetto Compressione
- SL** - Suction service valve - Rubinetto Aspirazione
- LPSV** - LP safety valve - Valvola sicurezza LP
- HPSV** - HP safety valve - Valvola sicurezza HP

NOTES

Note

//



DORIN WEB SOFTWARE

Open the camera app on your device and point it at the QR code to scan it. Make sure that all the four corners of the QR code are in view. A pop-up notification will appear on your screen, tap the notifications to launch the code.

Open the camera app on your device and point it at the QR code to scan it. Make sure that all the four corners of the QR code are in view. A pop-up notification will appear on your screen, tap the notifications to launch the code.

/ Open the camera app on your device and point it at the QR code to scan it. Make sure that all the four corners of the QR code are in view. A pop-up notification will appear on your screen, tap the notifications to launch the code. / Open the camera app on your device and point it at the QR code to scan it. Make sure that all the four corners of the QR code are in view. A pop-up notification will appear on your screen, tap the notifications to launch the code.



OFFICINE MARIO DORIN S.p.A.
Via Aretina 388, 50061 Compiobbi - Florence, Italy Tel.
+39 055 62321 1 - Fax +39 055 62321 380

dorin@dorin.com
www.dorin.com